

- Replaceable with pre-existing soap pump hole
- Easily rinse hard to reach areas of drinkware before they dry up.
- Easily installed to hot & cold supply lines.
- Mounts in a standard countertop hole.
- Powerful spray nozzle power away residue.
- Rinse a wide variety of cups, bottles & glasses.



C4400

Chrome Plated

Configurations:-

Part No	Includes
C4400-US	3/8" Angled valve
C4400-INT	Check valve Retainer
C4400-US-PR	3/8" Angled valve and Inline pressure Regulator
C4400-INT-PR	Check valve Retainer and Inline pressure Regulator

Product Dimensions:-

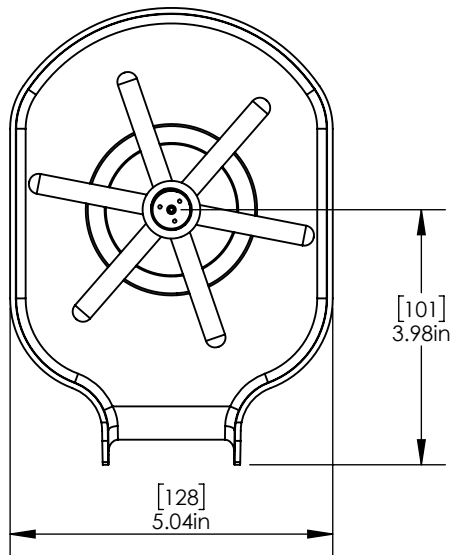

Top View

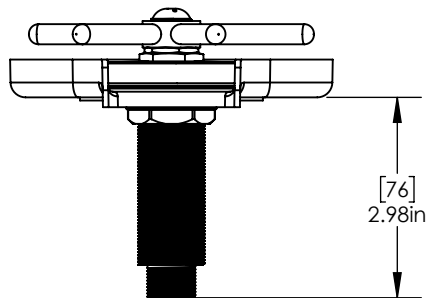

Front View

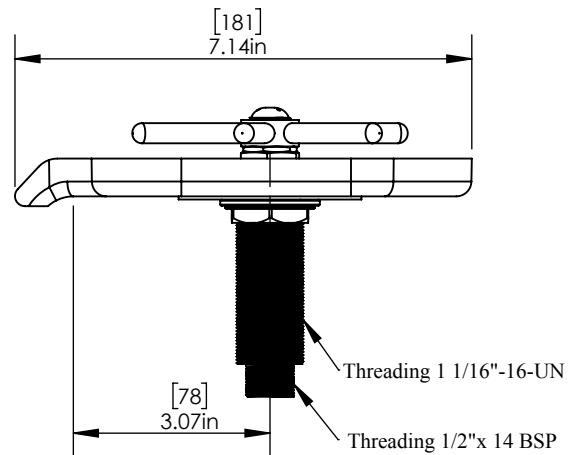

Side View