

### Features & Benefits:

- Open reel with epoxy coated steel finish
- (11m) Heavy duty blue hose
- Adjustable hose bumper



**C8270**

**Warranty:** One Year (Limited)

**Product Dimensions:-**

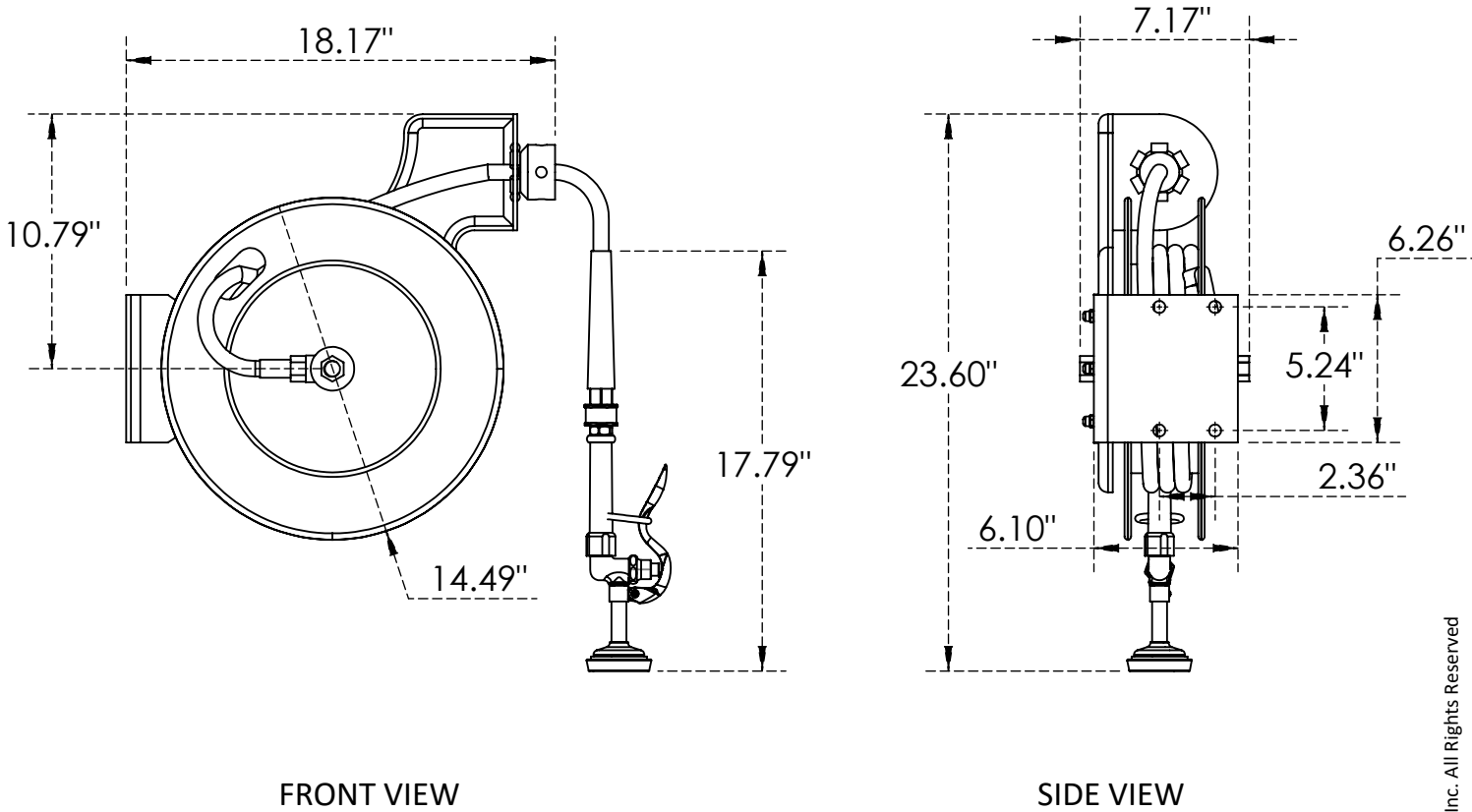

FRONT VIEW

SIDE VIEW

**Options available:-**

Part No.	Part Name
8269	Kitchen Cleaning Water Hose Reel 16mtr
8270	Kitchen Cleaning Water Hose Reel 11mtr

US & Canada :- +1-678 666 2001  
 Asia:- +91-9814203010

Krome USA Inc. reserves the right to make revisions to product specifications without any notice  
 For most updated specification sheet , go to [www.aluids.com](http://www.aluids.com)

