

PART NO.-

C9091 line drawing

TITLE-

Commercial Wall Mount Grab Bar with Concealed Screw 1-1/2",  
Vibrant Stainless

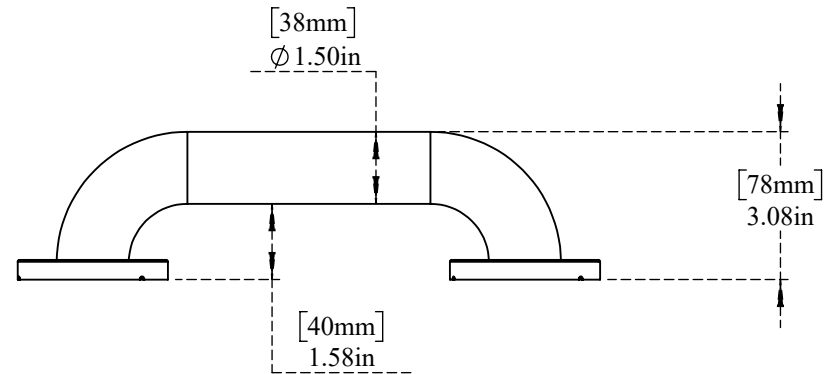
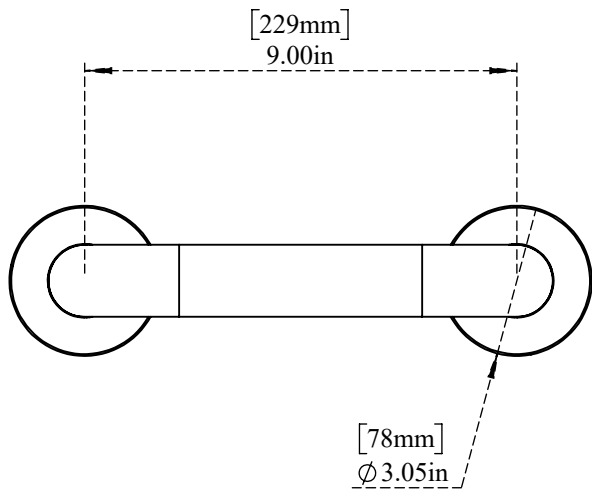
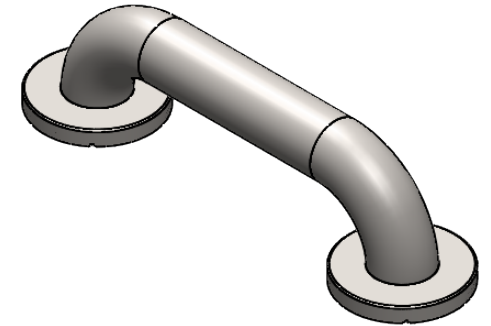

**ALUIDS**

Note:- Information provided for reference only.

All dimensions are in inches, mm (in bracket)

\* This document and the information thereon is the property of Krome Dispense Pvt Ltd. & its subsidiaries. Any reproduction in part or as a whole without the written permission of Krome Dispense Pvt Ltd. is prohibited.