

Features & Benefits:

- Faucet with 8" Centers.
- Built-in Quarter Turn Cartridges.
- Includes 1/2" Female Inlet (C8121).
- Inlet Kit (C8118) Sold Separately.
- 1.2GPM @ 60PSI Spray Valve.
- 18" Riser Tube.
- Lever Handles with Color Coded Red & Blue Indexes.
- Add-On Faucet with 8" spout.



C8470

Warranty: Four Year (Limited)

Product Dimensions:-

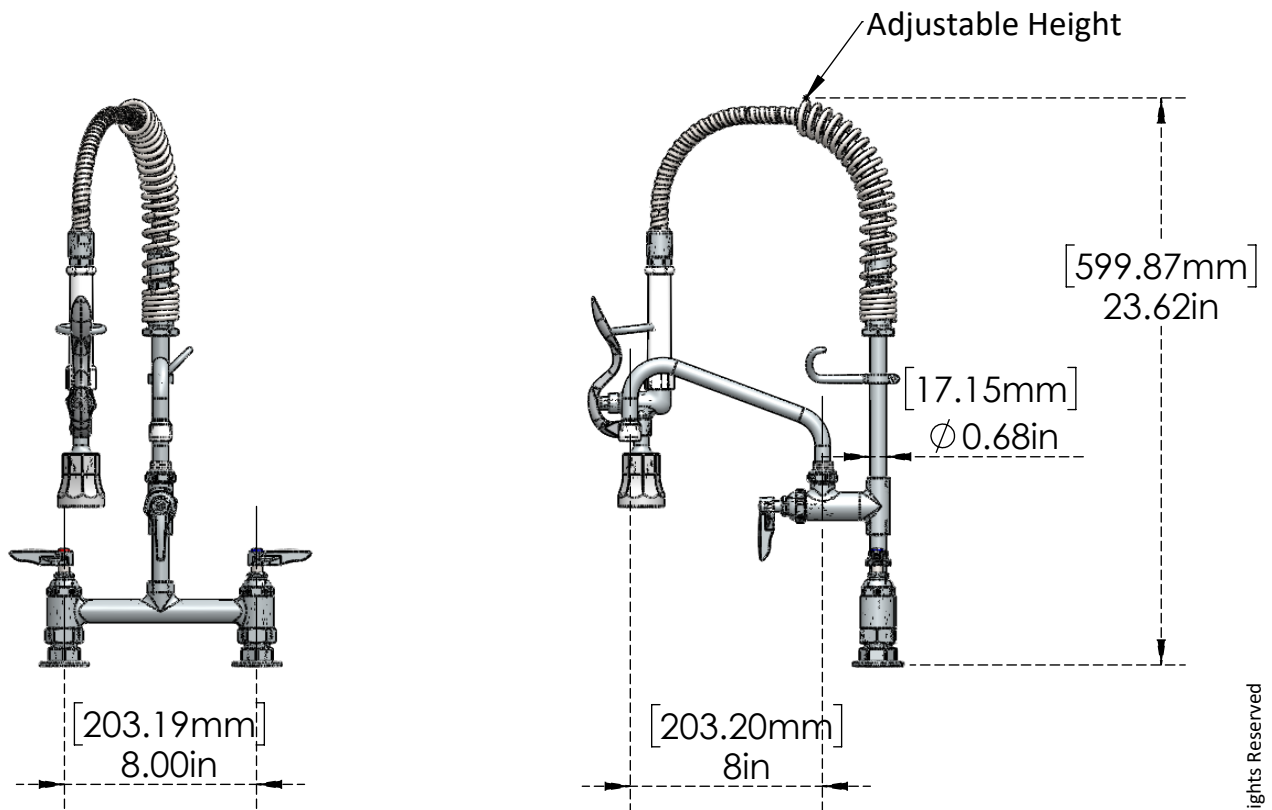

Options Available:-

Part No	Name	Spray Valve(@ 60PSI)	Finish	Mounting System	Center Distance	Inlet	Add on Faucet
C8199	Pre-Rinse Unit: 1.42 GPM , 8" Center Deck Mount	1.2 GPM	Polished Chrome	Deck Mount	8"	1/2" NPT	No

US & Canada :- +1-678 666 2001
 Asia:- +91-9814203010

Krome USA Inc. reserves the right to make revisions to product specifications without any notice
 For most updated specification sheet , go to www.aluids.com

ALUIDS