

For Residential and Commercial Applications

Job Name _____
 Job Location _____
 Engineer _____
 Approval _____

Contractor _____
 Approval _____
 Contractor's P.O. No. _____
 Representative _____

Series:

6" Wide Double Bend Spout
 C8547

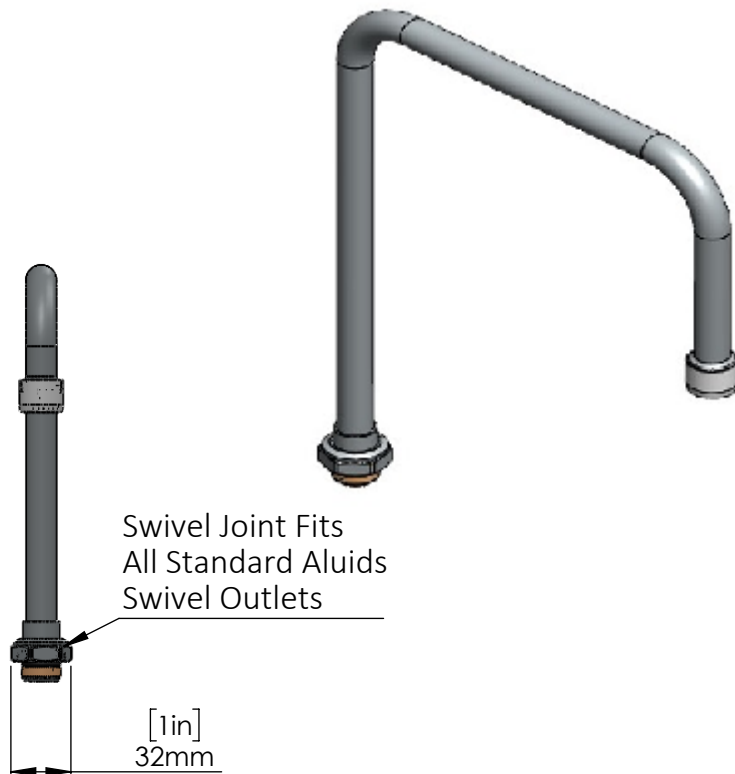
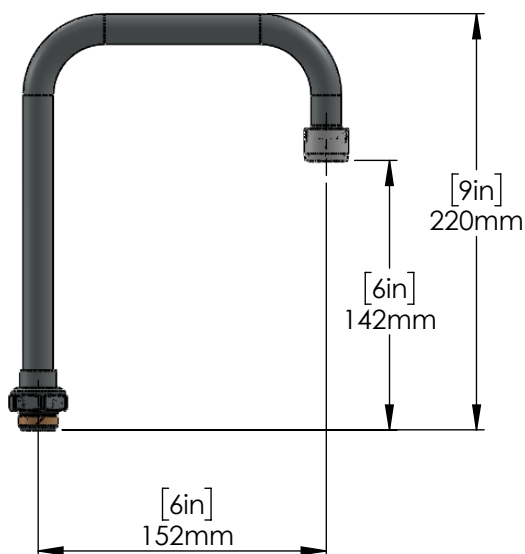

Features & Benefits:

- Double Bend Spout with 4" Center deck mount faucet
- lever handles and durable full range 6" Wide Double Bend Spout
- Lead free Brass Spout and 1/2" NPT male inlets
- Aerator Holder and Rubber washer Sub-Assembly
- finish is polish CP

Product Compliance:

- California proposition 65

Warranty: One Years (Limited)

NOTICE

The information contained herein is not intended to replace the full product installation and safety information available or the experience of a trained product installer. You are required to thoroughly read all installation instructions and product safety information before beginning the installation of this product.

Performance Data:

- Pressure: 20 - 125 psi
- Temperature: 40° F - 140° F
- Foam flow Aerator



US & Canada :- +1-678 666 2001

Krome product Specifications in U.S. customary units and metric are approximate and are provided for reference only. For precise measurements, please contact Krome Technical Service. Krome reserves the right to change or modify product design, construction, specifications, or materials without prior notice and without incurring any obligation to make such changes and modifications on Krome products previously or subsequently sold. For most updated specification sheet, go to