

For Residential and Commercial Applications

Job Name _____
Job Location _____
Engineer _____
Approval _____

Contractor _____
Approval _____
Contractor's P.O. No. _____
Representative _____

Series:

Double Pantry Wall Mount Swivel Base Faucet with 8" Swing Nozzle
C8453

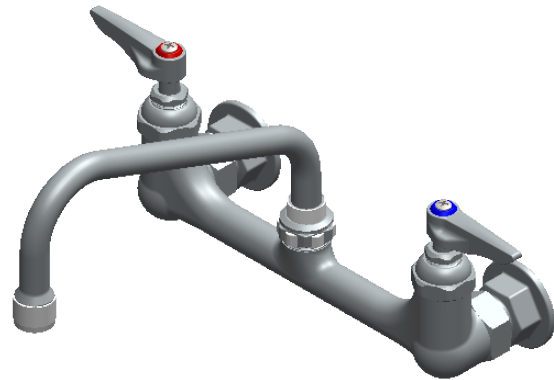
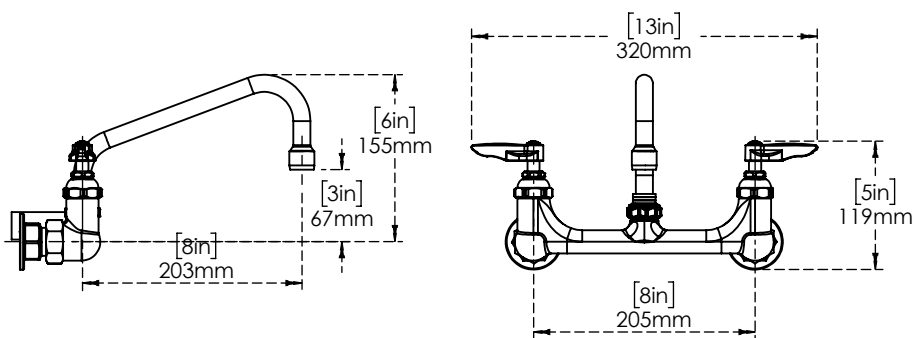

Features & Benefits:

- 10" Swing Nozzle stream regulator outlet
- 1/2" NPT Female Eccentric Flange
- Lever Handles with HOT & COLD Indexes
- Compression cartridges with spring checks
- Adjustable centers from 7 3/4" to 8 1/4"

Product compliance:

- California proposition 65

Warranty: one years(Limited)

Performance Data:

- Pressure: 20 - 125 psi [1.38 - 8.62 bar]
- Temperature: 40° F - 140° F [4.44 C - 60 C]

NOTICE

The information contained herein is not intended to replace the full product installation and safety information available or the experience of a trained product installer. You are required to thoroughly read all installation instructions and product safety information before beginning the installation of this product.

ALUIDS

US & Canada :- +1-678 666 2001

Krome product Specifications in U.S. customary units and metric are approximate and are provided for reference only. For precise measurements, please contact Krome Technical Service. Krome reserves the right to change or modify product design, construction, specifications, or materials without prior notice and without incurring any obligation to make such changes and modifications on Krome products previously or subsequently sold. For most updated specification sheet, go to