

# For Residential and Commercial Applications

Job Name \_\_\_\_\_  
 Job Location \_\_\_\_\_  
 Engineer \_\_\_\_\_  
 Approval \_\_\_\_\_

Contractor \_\_\_\_\_  
 Approval \_\_\_\_\_  
 Contractor's P.O. No. \_\_\_\_\_  
 Representative \_\_\_\_\_

## Series:

8" Center Wall Mount Utility Spray  
 C8593

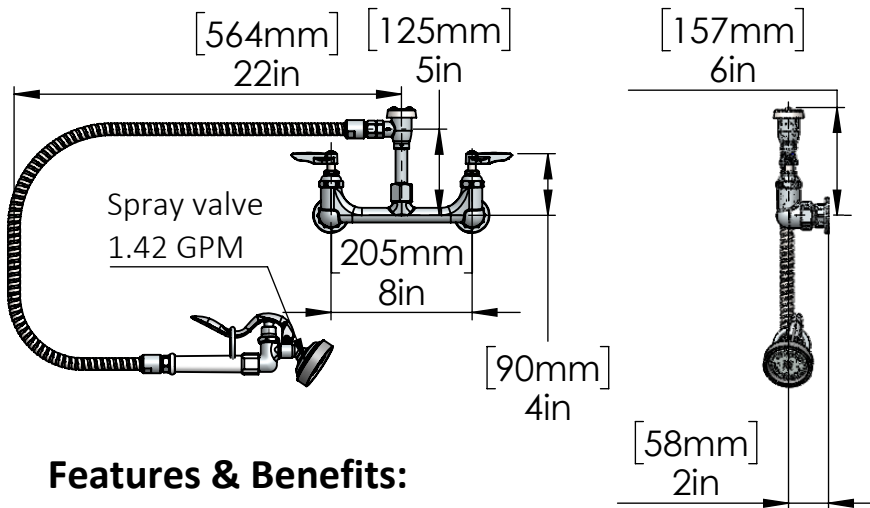

### Features & Benefits:

- Wall Mount 8" Centers
- 1/2" NPT Female Eccentric Flange
- Lever Handles with HOT & COLD Indexes
- Compression cartridges with spring checks
- 8" Adjustable Centers
- includes 3/8" Atmospheric Vacuum Breaker, 72" SS Flexible Pipe for PreFaucet
- Grip Handle, nipple, 3/8" NPT x 3
- Female connector 3x18" NPT to 1"x20 UNEF, Male Connector 3/8" NPT to 3/4 UNS,
- Angled Pre-Rinse Spray Head-1.42 GPM.

### Product Compliance:

California proposition 65

### Performance Data:

- Pressure: 20 - 125 psi
- Temperature: 40°F - 140°F
- Flow Rate: 1.42 GPM @ 60 psi

**Warranty:** One Years

**Material:** Stainless steel

### NOTICE

The information contained herein is not intended to replace the full product installation and safety information available or the experience of a trained product installer. You are required to thoroughly read all installation instructions and product safety information before beginning the installation of this product.

### Optional Pre-Rinse Spray Valves:

Spray Valve	Flow Rate
C9520	1.42GPM
C8249	4.50GPM
C8149	1.42GPM
C9526	1.15GPM



US & Canada :- +1-678 666 2001

Krome product Specifications in U.S. customary units and metric are approximate and are provided for reference only. For precise measurements, please contact Krome Technical Service. Krome reserves the right to change or modify product design, construction, specifications, or materials without prior notice and without incurring any obligation to make such changes and modifications on Krome products previously or subsequently sold. For most updated specification sheet, go to