

For Residential and Commercial Applications

Job Name _____
 Job Location _____
 Engineer _____
 Approval _____

Contractor _____
 Approval _____
 Contractor's P.O. No. _____
 Representative _____

Series

Commercial Stainless Steel Work Table
C9130 -EL

Dimensions:

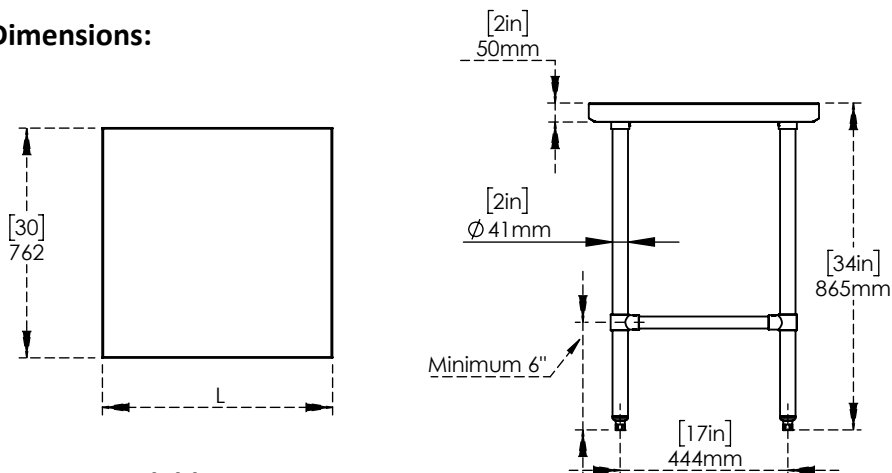

Option Available:

Part No.	Part Name	length (L)	No. of Legs
C9130-24-EL	30" x 24" Stainless Steel Work Table	24"	4
C9130-30-EL	30" x 30" Stainless Steel Work Table	30"	4
C9130-36-EL	30" x 36" Stainless Steel Work Table	36"	4
C9130-48-EL	30" x 48" Stainless Steel Work Table	48"	4
C9130-60-EL	30" x 60" Stainless Steel Work Table	60"	4
C9130-72-EL	30" x 72" Stainless Steel Work Table	72"	4
C9130-84-EL	30" x 84" Stainless Steel Work Table	84"	6
C9130-96-EL	30" x 96" Stainless Steel Work Table	96"	6

Features & Benefits:

- It is made of stainless steel 430 grade, 18 gauge.
- Adjustable and foldable, flat packed.
- Galvanized legs with 1.5mm thickness.
- It's light easy to drag about.
- This will be Perfect for use in the kitchen.
- It may also serve as a work desk in your office.
- It is a vital component of any home furnishings.
- NSF/ANSI 2

NOTICE

The information contained herein is not intended to replace the full product installation and safety information available or the experience of a trained product installer. You are required to thoroughly read all installation instructions and product safety information before beginning the installation of this product.



US & Canada :- +1-678 666 2001

Krome product Specifications in U.S. customary units and metric are approximate and are provided for reference only. For precise measurements, please contact Krome Technical Service. Krome reserves the right to change or modify product design, construction, specifications, or materials without prior notice and without incurring any obligation to make such changes and modifications on Krome products previously or subsequently sold. For most updated specification sheet, go to