

For Residential and Commercial Applications

Job Name _____
 Job Location _____
 Engineer _____
 Approval _____

Contractor _____
 Approval _____
 Contractor's P.O. No. _____
 Representative _____

Series:

Ecoline SINGLE HOLE FAUCET DECK MOUNT with 10" spout - Mixing faucet - Ceramic cartridges - 2.2 GPM with inlet tubings

C9174

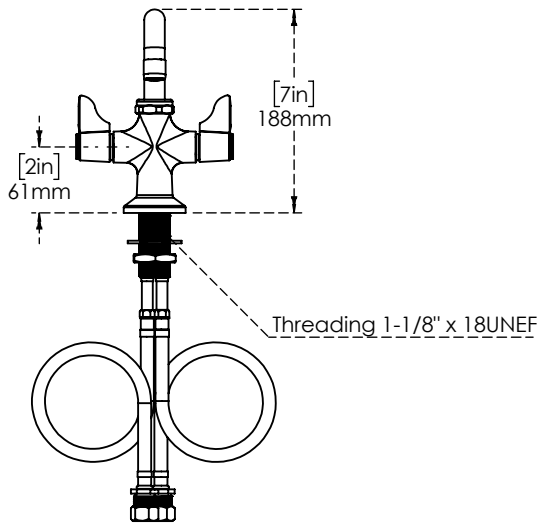
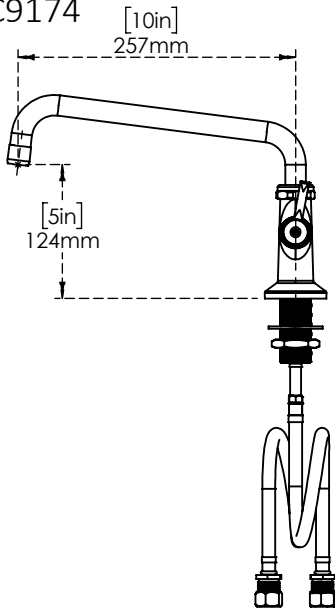

Features & Benefits:

- 18" stainless steel flexible supply hoses with 1/2" NPSM inlet
- cartridges Spindle : Ceramic cartridges
- Deck mount mixing faucet with a single hole and a polished chrome plated brass body.
- Swivel outlets are compatible with equip swivel goosenecks.
- Double Lever Handle.
- Pressure Max: 125 psi.
- Pressure Min: 20 psi.
- Temperature Max: 140 F.
- Temperature Min: 40 F.

Optional Cartridges:

- Quarter-Turn w/ Spring Check valve
- Quarter-Turn w/ Check Valve

Performance Data:

- Pressure: 20 - 125 psi [1.38 - 8.62 bar]
- Temperature: 40° F - 140° F [4.44 C - 60 C]
- Flow rate : 2.2 GPM [4.35 L/min] @ 60 psi

Product compliance:

- California proposition 65

Warranty: one years(Limited)

NOTICE

The information contained herein is not intended to replace the full product installation and safety information available or the experience of a trained product installer. You are required to thoroughly read all installation instructions and product safety information before beginning the installation of this product.



US & Canada :- +1-678 666 2001

Krome product Specifications in U.S. customary units and metric are approximate and are provided for reference only. For precise measurements, please contact Krome Technical Service. Krome reserves the right to change or modify product design, construction, specifications, or materials without prior notice and without incurring any obligation to make such changes and modifications on Krome products previously or subsequently sold. For most updated specification sheet, go to